

# WHEATON® UniSpense® PRO Peristaltic Pump

## Instruction Manual



OmniSpense® ELITE



UniSpense® PRO

Catalog Numbers:

**W375040-A and W375040-B (100-120V)  
and W375040-C through W375040-J (220-240V)**

---

# Table of Contents

<b>1.0</b>	<b>Warranty</b>
<b>2.0</b>	<b>Safety Symbols and General Safety</b>
<b>3.0</b>	<b>Specifications</b>
<b>4.0</b>	<b>Introduction</b>
4.1	The Peristaltic Pump Process
4.2	Typical Applications
4.3	Initial Inspection
<b>5.0</b>	<b>Unit Features and Component Identification</b>
5.1	Control
5.2	User Interface
5.3	Performance Highlights
<b>6.0</b>	<b>Installation</b>
6.1	Initial Power Requirements
6.2	Power Cord Set
<b>7.0</b>	<b>Initial Startup and Operation</b>
7.1	Pump Head Attachment and Tubing Installation
7.2	Tubing Characteristics
7.3	Switching the Unit ON
7.4	Keypad Functions and Icons
7.5	Footswitch Operation and Connector Functions
7.6	Flexible Tubing Holder
<b>8.0</b>	<b>Unit Setup</b>
8.1	Language Selection
8.2	Buzzer Function
8.3	Unit Reset
<b>9.0</b>	<b>Preparing for Batch and Single Dose Dispensing</b>
<b>10.0</b>	<b>Making a Calibration</b>
10.1	Setting Operating Speed
10.2	Priming the Tubing
10.3	Calibration Dispense
<b>11.0</b>	<b>Making Batch and Single Dose Dispenses</b>
11.1	Batch Count
11.2	Volume per Dispense
11.3	Delay Between Dispenses
11.4	Making a Dispense
11.5	To Adjust the Volume During a Batch Dispense
11.6	To Run Additional Batches with the Same Settings
<b>12.0</b>	<b>Memory Storage and Recall</b>
12.1	To Store a Parameter
12.2	To Recall a Parameter
<b>13.0</b>	<b>Tips for Obtaining Maximum Accuracy</b>
<b>14.0</b>	<b>Maintenance and Troubleshooting</b>
14.1	Maintenance
14.2	Troubleshooting – For Qualified Maintenance Personnel Only
14.3	Fuse Replacement
<b>15.0</b>	<b>Illustrations and Diagrams</b>
<b>16.0</b>	<b>Declarations of Conformity and WEEE Statement</b>

## Unispense Pro Parts Lists and Illustrations

FIG A	Major Component Identification
FIG B	Lower Housing Assembly
FIG C	Upper Housing Assembly
FIG D	Complete Assembly
FIG E	Wiring Diagram
FIG F	Remote Footswitch Connector and Pin Outs

### Limited Warranty

All goods and materials shall conform to WHEATON Industries Inc. specifications at the time of shipment from our plant. WHEATON Industries warrants this product to be free from defects in material and workmanship for a period of 365 days from the date of shipment. If the repair or adjustment is necessary within the warranty period and has not been the result of mishandling or abuse, WHEATON will either correct the non-conforming condition, or replace any nonconforming goods or materials or issue a credit in the amount of the purchase price paid and received for such goods. All claims for product nonconformity must be made within ten (10) days of identifying such a problem by calling Customer Service at 800.225.1437 (U.S., Puerto Rico and Canada); or Internationally at 856.825.1100 and then providing the Model, Serial and Catalog Number of the product. Items returned are to be packed very carefully so as to prevent damage in transit. WHEATON will also repair or adjust any product that is beyond the warranty period for a nominal fee.

**WHEATON makes no other express or implied warranty, statutory or otherwise, concerning materials or goods supplied, including without limitation, ANY WARRANTY of fitness for a particular purpose or any warranty of merchantability. The warranties given are exclusive of all other warranties expressed or implied. WHEATON shall not be liable for consequential, special or incidental damages.**

To expedite any technical or service request, please have the following information available. Thank you.

Model: \_\_\_\_\_  
 Serial #: \_\_\_\_\_  
 Catalog #: \_\_\_\_\_

### Safety Symbols Used in this Manual and On This Product



A **WARNING** symbol indicates attention to an operation which can cause operator injury, improper function of or damage to the equipment and possible problems with the process.



An **ELECTRICAL DANGER** symbol indicates attention to an operation which could cause electrocution or severe injury.

## General Safety Rules



**WARNING. READ AND UNDERSTAND ALL INSTRUCTIONS.** Failure to follow all instructions listed below may result in electrical shock, fire and / or serious personal injury.

### SAVE THESE INSTRUCTIONS

- 1. Know your instrument** - Read the operating manual carefully. Learn the equipment's application and limitations.
- 2. Ground all equipment** - If electrical, this instrument is equipped with a grounding type plug. The green/yellow conductor in the cord is the grounding wire and should never be connected to a live terminal.
- 3. Avoid dangerous environment** - Electrical instruments designed to process liquids must be operated with extreme caution. If liquid comes in contact with internal electrical components or wires, fire or electrical shock may occur. Adequate surrounding work space should be provided during use. Do not operate electrical instrumentation in a combustible atmosphere.
- 4. Work surface** - Keep well lighted. Be certain the work surface is clean, level and sturdy enough to support the weight of the unit, particularly if it is to be filled with liquid.
- 5. Wear proper apparel** - Do not wear loose clothing, neckties or jewelry that might get caught in moving parts. Non-slip footwear is recommended. Wear protective hair covering to contain long hair.
- 6. Wear safety goggles** - Wear safety goggles at all times. Everyday eyeglasses only have impact resistant lenses, they are NOT safety glasses.
- 7. Don't Overreach** - Keep proper footing and balance at all times.
- 8. Maintain instrument with care** - Keep screws tight and unit clean. Check periodically for worn or damaged parts. Inspect the plug and cord before each use. Do not operate this instrument if there are signs of damage.
- 9. Avoid accidental start up** - If electrical, always make sure the switch is in the "OFF" position before plugging instrument into outlet.
- 10. Disconnect Instrument** - Always disconnect the instrument from the power source before servicing.
- 11. Do not block cooling vents if provided.**
- 12. Do not operate this equipment in any manner not specified in this manual.**
- 13. It is recommended that a fire extinguisher always be located in areas where electrical instruments are being used.**

## Specific Safety Considerations



**WARNING ! IMPROPER GROUNDING CAN RESULT IN ELECTRICAL SHOCK. IN THE EVENT OF A SHORT CIRCUIT, GROUNDING REDUCES THE RISK OF SHOCK. THIS INSTRUMENT MUST BE GROUNDED.**

This instrument is equipped with a cord having a grounding wire and an appropriate grounding plug. The plug must be used with an outlet that has been installed and grounded in accordance with all local codes and ordinances. The outlet must have the same configuration as the plug. **DO NOT USE AN ADAPTER.**

Do not modify the line cord that has been provided. If it does not fit the available outlet, contact your nearest WHEATON Industries distributor for the proper line cord for your geographic area.

### 3.0 Specifications – UniSpense Pro™

<b>Operating Voltage:</b>	Nominal 120-240 VAC 50/60 Hz
<b>Power Consumption:</b>	140 watts maximum
<b>Fuses:</b>	2.0 AT 5X20MM 250V – (100-120V) 1.0 AT 5X20MM 250V – (220-240V)
<b>Fixed Operating Speeds:</b>	75 and 150 RPM (selectable)
<b>Installation Category:</b>	Class II
<b>Environmental:</b>	Operating temperature: 15°C to 40°C Humidity: 80% up to 31°C / 50% at 40°C Altitude limit: 2000 meters
<b>Overall Dimensions:</b> (includes attached pump head)	7" H x 8 ¾" W x 13" D (in) 17.8H x 22.3W x 33.0D (cm)
<b>Weight:</b>	11.8 lbs, 5.4 kg
<b>Available WHEATON Tubing Sizes:</b>	2,3,6,8 mm ID
<b>Maximum Dispense Range for All Tubing Sizes:</b>	.01 - 9999.99 mL
<b>Approximate Flow Rate Ranges For Various Tubing Sizes, +/- 3%:</b>	2.0mm ID: 0.5 mL/sec and 1.0 mL/sec 3.0mm ID: 1.0 mL/sec and 2.0 mL/sec 6.0mm ID: 3.5 mL/sec and 7.1 mL/sec 8.0mm ID: 5.6 mL/sec and 11.2 mL/sec
<b>Vertical Head Height:</b>	APPROXIMATELY 6 FT (2 METERS)
<b>Ingress Protection Rating:</b>	31

### 4.0 Introduction

The UniSpense® PRO is the latest generation liquid dispenser from WHEATON Industries, Inc., which features precision microprocessor control of a wide range of dispensing parameters. Simplicity in operation is realized in the complete elimination of pump contamination during the dispensing process as fluid remains in the bore of the tubing and never touches any of the pump mechanism. As long as tubing sterilization concerns are satisfied, the dispensing process can be easily controlled for quality.

## 4.1 The Peristaltic Pump Process

Fluid is contained within a flexible tube, which is placed in the precision pump head. The center rotor, with a number of rollers, compresses the flexible tube. As the rotor turns, the part of tube under compression closes and forces the fluid to be pumped to move through the tube. After the roller passes, the tube opens to its natural state and fluid flow is induced to the tubing. This process is called peristalsis.

## 4.2 Typical Applications

Peristaltic pumps can be used with a large variety of liquids. Particularly corrosive, abrasive and suspension liquids are all good candidates for peristaltic pump applications.

Peristaltic pumps require little maintenance, are easy to install, have few moving parts, and are easy to use.

## 4.3 Initial Inspection

When you receive your new UniSpense® PRO, inspect it for any obvious damage that may have occurred during shipment. If any damage is found, notify the carrier at once. Warranty information is provided at the front of this manual. Check to confirm that there are no broken switches, displays or pump heads, and that the unit is not dented or scratched. Retain packaging until all parts and unit functionality are confirmed.

## Components Supplied

- **UniSpense® PRO** peristaltic pump
- **Pump Head**
- **Line Cord** – supplied to fit your local electrical outlet specifications
- **Flexible Tubing Holder**
- **Operators manual**
- **Quick Start Card**
- **Icon Help Sticker**

## 5.0 Unit Features and Components Identification

Refer to **Figure A** for component identification

**Power inlet module:** Location of the line cord entry and fuse(s) compartment.

**Keypad:** Allows all setting and operation parameters to be entered.

**Screen:** A unique iconic-driven display allows easy access and viewing of unit functions and parameters.

**I/O Interface Connection:** Allows connection of either the included handset, or an optional footswitch. Also contains feedback outputs for remote PLC control.

**Pump Head:** Other optional pump heads can be mounted on the unit, (see section 6.1). Tubing is loaded by simply raising the cover on the pump head, and snapping closed

## 5.1 Control

The UniSpense® PRO can be used in both laboratory and industrial settings. In addition to the front-panel keypad, the pump can be triggered to run remotely either by the optional footswitch, or by a dry contact relay or isolated open collector transistor output as part of a more advanced automated dispensing system. The UniSpense® PRO is capable of sending an End of Dispense (EOD) feedback signal to a controller for remote automated operation.

## 5.2 User Interface

A chemical resistant membrane keypad allows direct user entry of volume, tubing size, automatic delay interval, ramp time, pump direction, pump speed, pump function and dose count. Additional user selective functions include calibration, memory functions and audible cycle alert. The self-prompting, symbolic LCD screen ensures quick setup and ease of operation.

## 5.3 Performance Highlights

An adjustable ramp feature allows the pump to come up to speed gradually and helps prevent foaming or splashing when dispensing into dishes or small vials. An adjustable delay can be set from 0.5 to 99.9 seconds between doses to accommodate user dexterity and work load. The pump can be activated by depressing either the front panel mounted start key, or the optional footswitch for hands-free operation.

Up to 9 pre-selected set-ups can be stored in memory and quickly retrieved for later use. Selections stored in memory are preserved even after powering the unit down. Pump speed is selectable at 75 and 150 RPM. A flexible tubing support stand is included to facilitate hands-free operation.

## 6.0 Installation

Install the unit where there will be adequate room for the unit to operate. Provide enough clearance around the unit to keep items away from the rotating pumps and tubing.

### 6.1 Input Power Requirements

This equipment is designed to operate from a 100-120V single-phase AC power source at 47 to 63 Hz. The line voltage / fuse label located on the lower rear of the unit shows the nominal input voltage set for the unit at the factory.

### 6.2 Power Cord Set

This unit has been shipped from the factory with a power line cord that has a plug appropriate for your area. If the wrong power cord has been shipped for your particular application, contact your nearest WHEATON Industries dealer for the proper cord. The UniSpense® PRO has been equipped with a 3-wire grounding type power cord. The unit is only grounded when it is plugged into an appropriate receptacle. **Do not operate the unit without adequate grounding protection.**

## 7.0 Initial Startup and Operation



**CAUTION:** Keep hands and fingers away from rotating parts of the machine. Make sure tubing is secured and clamped properly before running pump. Pump should be turned off and unplugged while loading tubing into pump head.

## 7.1 Pump Head Attachment and Tubing Installation



**Pump Head Setup** - Raise the cover on the pump head so that the arrow (upper left) points to the mark on the pump frame. Identify the tubing bore diameter from the tubing manufacturer's packaging. Using the graduations on the side of the head, adjust the tubing clamps on both sides via the thumbscrews at the bottom of the pump head to the proper tubing bore size.



**Pump Head Attachment** - Align the pump drive shaft tang with the drive rotor slot on the back of the head. Align the slots on the back of the head with the ears on the pump head mounting plate. Place the pump head on the mounting plate and twist the pump head clockwise until it clicks into place.



**Tubing Installation** – Insert Tubing into the pump head between the pump head cover and the rollers. Close the pump head cover to secure the tubing. Make sure tubing is not twisted and has no kinks.



**CAUTION! Improper adjustment of the tubing clamps may result in improper performance of tubing, or premature wear and failure of tubing. DOUBLE CHECK clamp settings before proceeding.**

Make note of which end of the tubing will be the inlet and which end of the tubing will be the outlet (left or right).



**To Remove Pump Head** – Press the release tab at the lower right of the pump head. While holding the release tab, rotate the pump head counterclockwise and pull off.

## 7.2 Tubing Characteristics

Silicone tubing exhibits a wide range of chemical resistivity and should be suitable for most general dispensing applications. However, there are a few organic substances which cannot be dispensed accurately due to their effects on silicone tubing. These substances include hydrocarbons, acids and halogenated hydrocarbons. To determine if a particular tubing-chemical combination is compatible, immerse a 100mm length of tubing in the chemical in question for 72 hours at room temperature. If after this time period the tubing has increased or decreased in length by less than 3%, the combination is compatible. Length changes of 3% to 8% are worth trying, but will not produce the most accurate results. Changes in length over 8% are considered to be unsatisfactory. It should also be noted that a new tubing assembly may cause slight filling variations for the first one to two hours of operation.



### 7.3 Switching the Unit ON

Switch the pump ON via the power switch on the rear panel. The main screen displays the WHEATON Industries logo and the firmware version level.

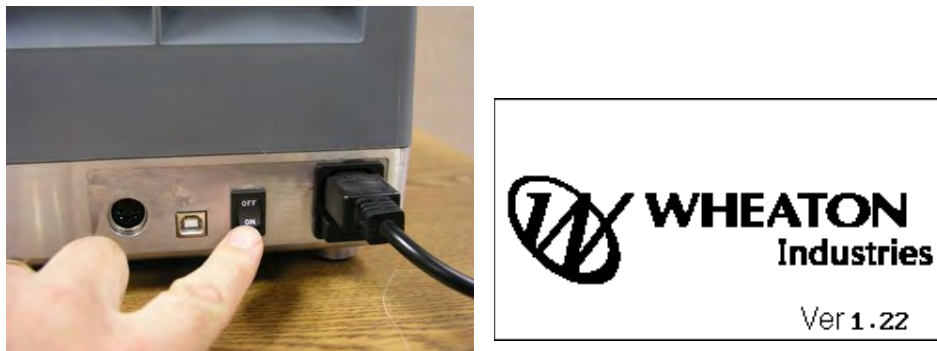



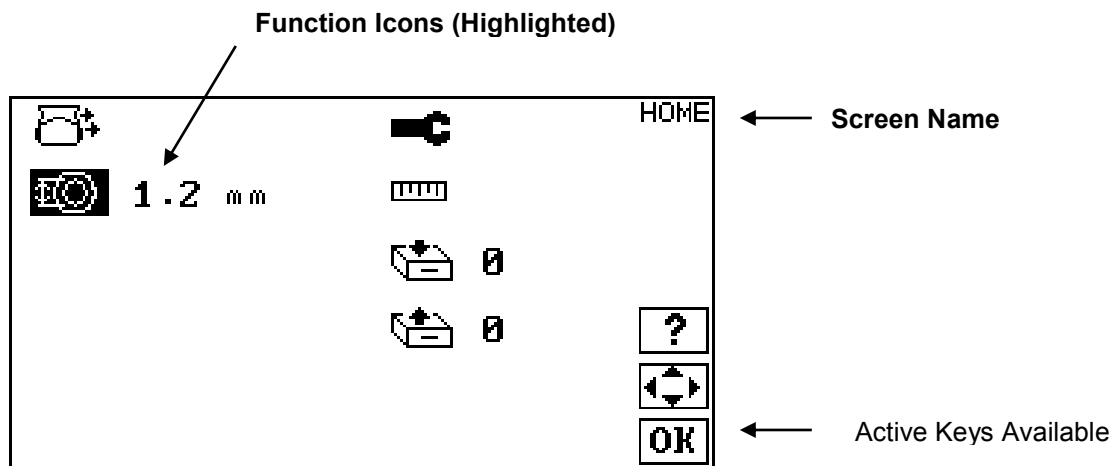

The pump will automatically transition to the **HOME** screen. Additional screens feature a similar layout:



### 7.4 Keypad Functions and Icons

Icons on the right of each screen show the user which keys will be active during function and setup navigation. A brief explanation of active keys is listed:

-  **Help** – Pushing the help button will show icon explanations in several languages
-  **Run/Stop** – Starts and stops the pump
-  **Prime** – Push and hold the button to run the pump at a fixed speed to purge air from the tubing
-  **Arrow Keys** – Used to navigate menu items, and adjust parameters and values
-  **OK** – Confirms an entry of a parameter or value

## 7.5 Footswitch Operation

Plug the optional foot switch into the Interface Connector found at the rear of the unit. If the unit is at idle, pressing the footswitch once, will initiate a pump dispensing sequence, as defined by the entries made by the user via the main front panel keypad. If the unit is running, pressing the footswitch once will stop the pump.



In addition to connections for the above footswitch, the interface Connector contains feedback pinouts for a Pump Running / Pump Stopped indicator.

Pins 1 (footswitch +) and 2 (footswitch GND) are +5V TTL compatible inputs with pull up resistors, and can be driven by an isolated open collector device or dry contact relay, to start and stop the unit.

Pins 3 and 5 are an isolated transistor output capable of driving a TTL load with pull up resistor. When the pump is **running**, the transistor is **ON**, and when the pump is **stopped**, the transistor is **OFF**.

See Figure F for connector pin out details.

## 7.6 Flexible Tubing Holder

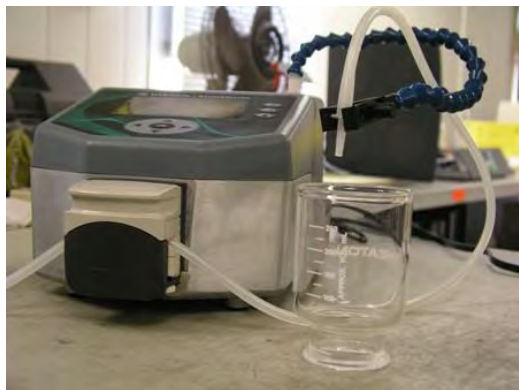

An included flexible tubing holder mounts to either side of the unit, and can be flexed to the desired position, for hands-free operation of unit.

## 8.0 Unit Setup

The setup menu contains a collection of lesser used functions of the unit. From the **HOME** screen, use the **UP** and **DOWN** keys to navigate to the **SETUP** icon, and then press **OK**.

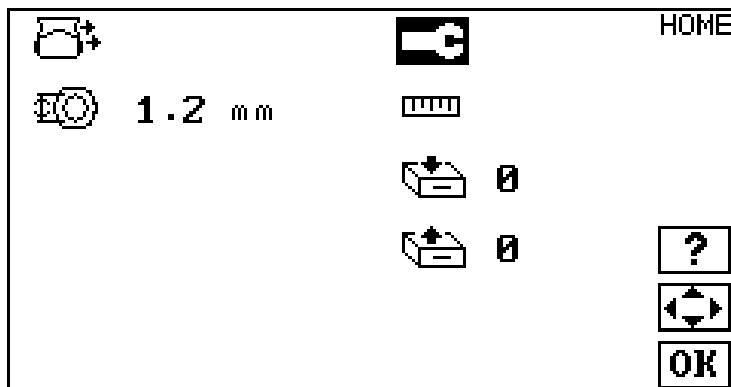

## 8.1 Language Selection

Press the **UP** and **DOWN** and the **LEFT** and **RIGHT** keys to access the **Language Selection**. Help screens are available in the following languages: English, French, German, Spanish, Japanese, Chinese, and Korean. Press **OK** when done.

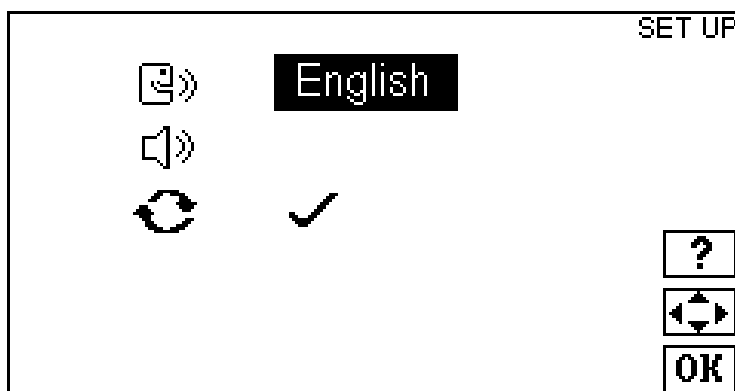

## 8.2 Buzzer Function

Press the **UP** and **DOWN** and the **LEFT** and **RIGHT** keys to access the **Buzzer Function**.



Turning the buzzer function **ON** will cause the unit to sound an end-of-dispense alert. Turning the buzzer function **OFF** (shown) will disable the buzzer during the dispense cycle.

## 8.3 Unit Reset

Press the **UP** and **DOWN** and the **LEFT** and **RIGHT** keys to access the **Unit Reset Function**.



**WARNING!** – Resetting the unit will return the unit to factory setup parameters. It will **NOT** clear any settings stored in memory as explained in the **MEMORY STORAGE AND RECALL** section.

To reset the unit, highlight the ‘check’ mark, and press **OK**. A special tone will sound when the unit resets.

## 9.0 Preparing for Batch and Single Dose Dispensing

Press the **OK** button to transition to the **HOME** screen. Set the tubing size by pressing the **UP** and **DOWN** keys to move to the tubing icon. Use the **LEFT** and **RIGHT** arrows to navigate the number fields, and the **UP** and **DOWN** icons to adjust the number fields. Press the **OK** button when done.



## 10.0 Making a Calibration

Use the **UP** and **DOWN** arrows in the **HOME** screen to navigate to the calibration icon.

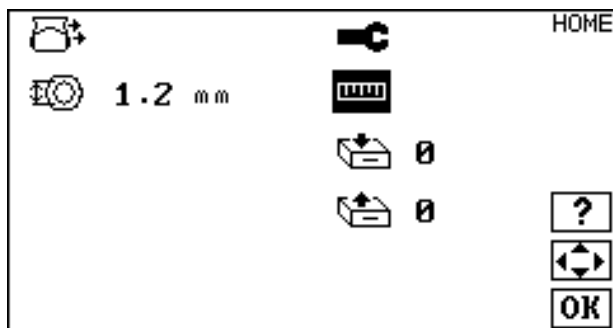

Press **OK** to navigate to the **CALIBRATE** screen.

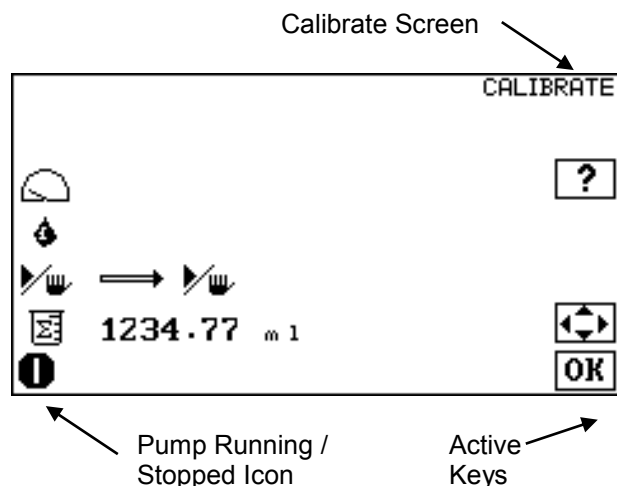

## 10.1 Setting Operating Speed

Use the **LEFT** and **RIGHT** buttons to select the operating speed:

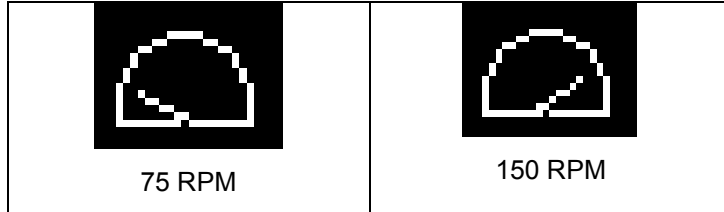

## 10.2 Priming the Tubing

Use the **UP** and **DOWN** buttons to select the **PRIME** icon. The PRIME button on the keypad now becomes active. Push and HOLD the prime button on the keypad to run the pump motor and purge any air from the tubing. RELEASE the prime button to stop the motor.

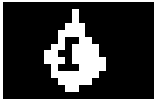

## 10.3 Calibration Dispense

Use the **UP** and **DOWN** button to navigate the **Calibration Dispense** icon:

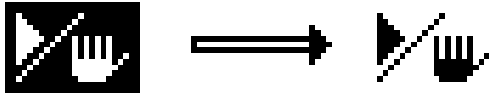

Prepare to measure a dispense by using a graduated cylinder, electronic scale, or other device that can accurately measure volume. Press the **START / STOP** button to begin a calibration dispense. **For best results, the pump rotor should make at least ten (10) revolutions.**

Press the **START / STOP** button to end the calibration dispense.



Use the **UP** and **DOWN** buttons and the **LEFT** and **RIGHT** buttons to enter the measured volume:

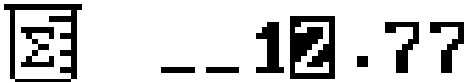

Press **OK** to enter the volume and complete the calibration procedure. Press **OK** again to return to the **HOME** screen.

## 11.0 Making Batch and Single Dose Dispenses

From the **HOME** screen, press **OK** to navigate to the DISPENSE SETUP screen:

Unit is in Dispense Setup Mode

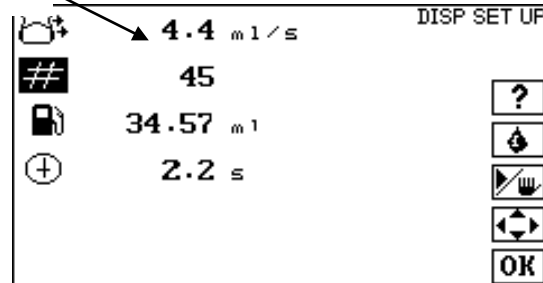

Active Keys

### 11.1 Batch Count

Use the **UP** and **DOWN** keys to navigate to the batch count:

# \_ \_ \_ \_ 45

Use the **UP** and **DOWN** and the **LEFT** and **RIGHT** keys to enter the batch count. Press **OK** when done.

### 11.2 Volume per Dispense

Use the **UP** and **DOWN** keys to navigate to the Volume per Dispense icon:

 34.57 ml

Use the **UP** and **DOWN** and the **LEFT** and **RIGHT** keys to enter volume per dispense. Press **OK** when done.

### 11.3 Delay Between Dispenses

Use the **UP** and **DOWN** keys to navigate to the Delay icon:

 2.2 s

Use the **UP** and **DOWN** and the **LEFT** and **RIGHT** keys to enter the delay between dispenses. Press **OK** when done.

## 11.4 Making a Dispense

Press the **START / STOP** button to start a batch dispense:

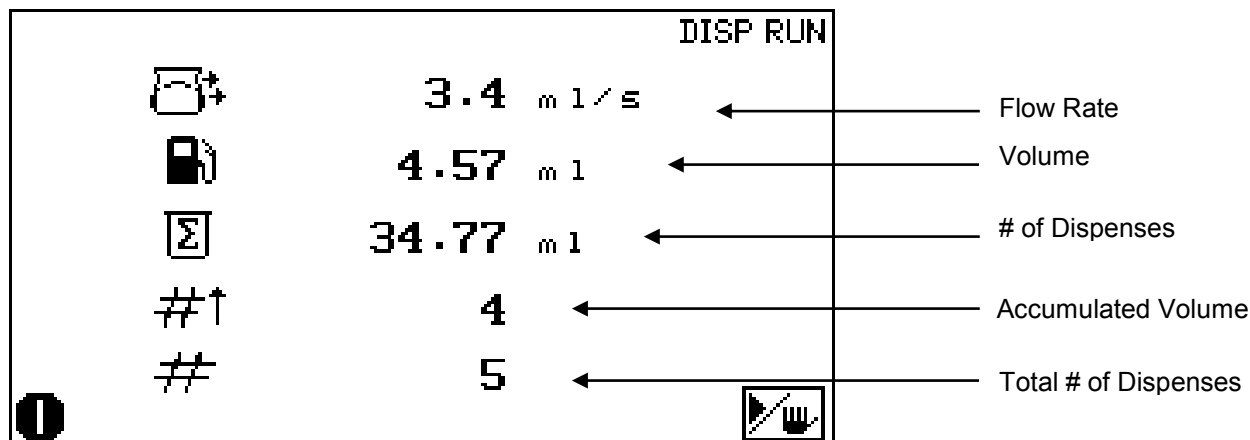

The pump will make dispenses with the settings programmed, and stop when the total number of dispenses are made.

## 11.5 To Adjust the Volume During a Batch Dispense

The dispensed volume can be adjusted during a batch dispense, by pressing the **Start / Stop** button, and then using the **UP** and **DOWN** and the **LEFT** and **RIGHT** keys to enter the dispense volume. Press **OK** when done. Press the **Start / Stop** button to resume batch dispensing.



## 11.6 To Run Additional Batches with the Same Settings

Press the **Start / Stop** button to start a fresh dispense batch.

## 12.0 Memory Storage and Recall - Available Registers: (1-9)

All set parameters, including set volume, delay interval, pressure release, dispense count, pump speed, ramp time, pump direction, etc. can be stored in non-volatile memory, and easily recalled. This is especially useful when the pump is used in several applications, each requiring its own particular setup parameters. Stored parameters can be quickly recalled, and the pump made ready for a particular operation.

### 12.1 To Store a Parameter

Set all pump parameters to desired settings. Navigate to the **HOME** screen and select the storage icon:

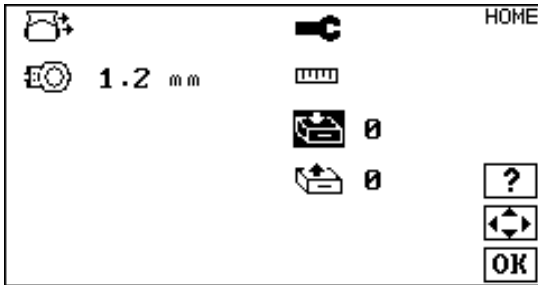

Use the **UP** and **DOWN** and the **LEFT** and **RIGHT** to select a storage register (1-9). Press the **OK** key to store parameters in non-volatile memory. A special tone will sound to confirm storage of parameters. If parameters are stored in a register already containing data, the old data will be overwritten with the new parameters.

### 12.2 To Recall a Parameter

Press the **UP** and **DOWN** and the **LEFT** and **RIGHT** keys to recall a storage register (1-9), and then press **OK**. A special tone will sound to confirm recall of parameters. If the unit appears to skip over certain registers when recalling a parameter, it means that the register skipped is empty. An empty storage register will not be accessible.

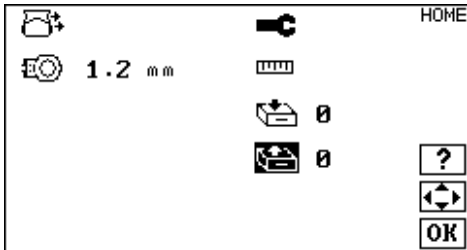

The contents of a **RECALL** register can be previewed by pressing the ? (info) key and pressing **OK** when done.

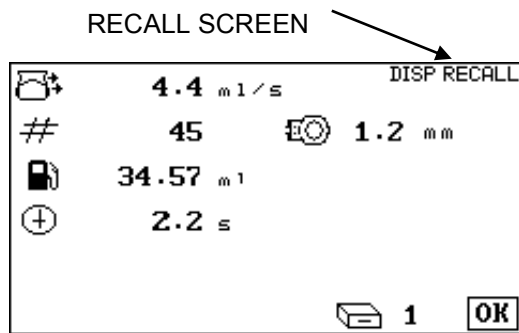

Previewing Memory Register #1



## 13.0 Tips on Obtaining Maximum Accuracy

Several operating variables must be considered in obtaining maximum dispense accuracy, such as tubing sizes, and pump speed. In addition other variables such as tubing characteristics (material, age, chemical compatibility) and pumped – medium characteristics (viscosity, chemical makeup, temperature) must also be considered in obtaining best dispensing results.

### Proper Tubing Selection

Each different tubing size will provide a different liquid delivery range when used in conjunction with the pump unit. Accuracy is increased as the number of pump head revolutions required per dispense is increased. Tubing size should be selected so the pump head makes at least 3 complete revolutions.

## 14.0 Maintenance and Troubleshooting



**DANGER! NEVER ATTEMPT TO PERFORM REPAIRS IF THIS INSTRUMENT IS PLUGGED IN! TO AVOID SERIOUS ELECTRIC SHOCK OR ELECTROCUTION, THIS INSTRUMENT MUST BE DISCONNECTED FROM THE SOURCE OF AC POWER BEFORE REMOVAL OF ANY PROTECTIVE COVERS.**

### 14.1 Maintenance

Routine user maintenance should include a regular inspection of the tubing assembly for excessive wear and leaks. Many service problems can often be cured by simply replacing a worn tubing assembly. To insure high accuracy, the pump rotor and tubing clamping mechanics of the pump head should be kept as clean as possible at all times.

The unit cabinetry has been designed to an IP31 rating. The plastic top is mineral filled polypropylene and the base is painted cast aluminum. The pump head and outer cabinet may be wiped down with warm water and any mild household cleaning solution. Never use abrasive cleaners or strong acids as cleaning solutions. Never place liquid containers on top of the UniSpense® PRO, as a spill could result in liquid entering the dispenser. If liquid should accidentally contact the front panel, the unit should be disconnected from the AC power source immediately and carefully dried with towels and warm air.

Although the UniSpense® PRO is designed for easy service, it is highly recommended that the instrument be returned to WHEATON Industries should any major repairs be needed.

Pump rollers can be occasionally lubricated with Teflon lubricating oil.

## 14.2 Troubleshooting – For Qualified Maintenance Personnel Only!



**DANGER! NEVER ATTEMPT TO PERFORM REPAIRS IF THIS INSTRUMENT IS PLUGGED IN ! TO AVOID SERIOUS ELECTRIC SHOCK OR ELECTROCUTION, THIS INSTRUMENT MUST BE DISCONNECTED FROM THE SOURCE OF AC POWER BEFORE REMOVAL OF ANY PROTECTIVE COVERS.**

### Unit will not operate:

- Cause:** Fuse blown.
- Remedy:** Replace fuse with proper size and type. (see 'Fuse Replacement')
- Cause:** Supply voltage low or at zero.
- Remedy:** Check house receptacle with a voltmeter.
- Cause:** On/Off power switch in "off" position.
- Remedy:** Switch power switch to "on" position.

### Motor runs but pump head will not turn;

- Cause:** Pump head not properly engaged with drive shaft.
- Remedy:** Realign pump head with drive shaft (see 'Initial Startup and Operation').

### Switch on but motor fails to rotate;

- Cause:** Pump speed set too low.
- Remedy:** Increase pump motor speed as required.
- Cause:** Motor control board defective.
- Remedy:** Replace defective board.
- Cause:** START Key not pressed.
- Remedy:** See 'Unit Features and Component Identification' for keypad and display operation.

### Unit will not cycle automatically:

- Cause:** Multiple doses are not entered.
- Remedy:** See 'Preparing for Batch and Single Dose Dispensing'.

## Troubleshooting – Continued

- Cause:** Dispense cycle not initiated.
- Remedy:** START key must be pressed to initiate the dispense cycle.

### Pump head turns, but unit will not pump;

- Cause:** Tubing assembly incorrectly installed.
- Remedy:** Tubing must be installed as described in section 'Initial Startup and Operation'.

**Cause:** Tubing assembly worn or split.  
**Remedy:** Replace tubing assembly.

**Motor fails to maintain constant rotation speed;**

**Cause:** Motor control board defective.  
**Remedy:** Have defective control board replaced.

**Cause:** Drive motor defective.  
**Remedy:** Have defective motor replaced.

**Liquid continues to drip from tubing even after pump has stopped;**

**Cause:** Tubing is worn.  
**Remedy:** Replace with fresh tubing.

**Cause:** Tubing ID mismatch with pump head used.  
**Remedy:** Tubing wall weight should match pump head specifications. See 'Accessories' section.

**Inaccurate Volume Delivery**

**Cause:** Tubing assembly worn.  
**Remedy:** Replace tubing assembly.

**Cause:** Pump not calibrated properly.  
**Remedy:** Calibrate unit as described in 'Making a Calibration' section.

**Cause:** Defective electronics.  
**Remedy:** Refer problem to authorized repair agent.

**Cause:** Side clamps on pump head not adjusted properly.  
**Remedy:** Adjust per instructions in 'Initial Startup and Operation'.

### 14.3 Fuse Replacement



**DANGER! BE CERTAIN THE UNIT IS DISCONNECTED FROM THE AC POWER SOURCE.**



1. Disconnect the cord-set from the AC power source.
2. Remove the fuse drawer by using a small flat screwdriver to lift the tab.
3. Replace with new fuses:

**108 - 120 vac unit use (2) 5x20mm, 250V, 2.0 AT fuses, be sure the correct cord set is used.  
220-240 vac unit use (2) 5x20 mm 240V 1.0 AT fuses, be sure the correct cord set is used.**



### WEEE STATEMENT

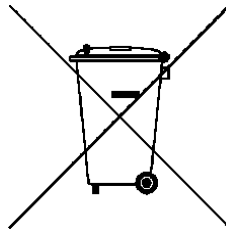

This UniSpense® PRO peristaltic pump is not to be discarded in typical trash outlets. This unit is to be discarded according to WEEE guidelines established in your area. There are no reusable parts. Contact the original distributor from which this product was purchased for proper disposal instructions.

**FIGURE A – Major Component Identification**

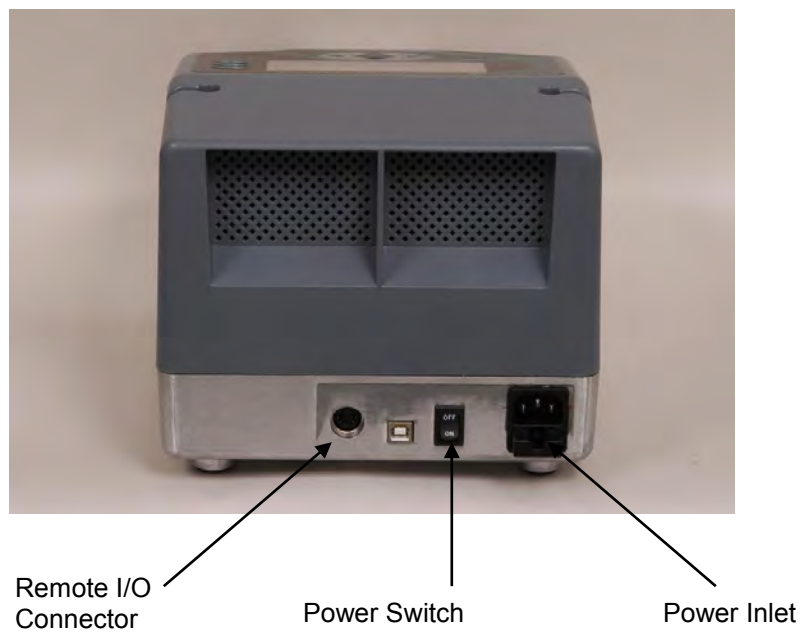
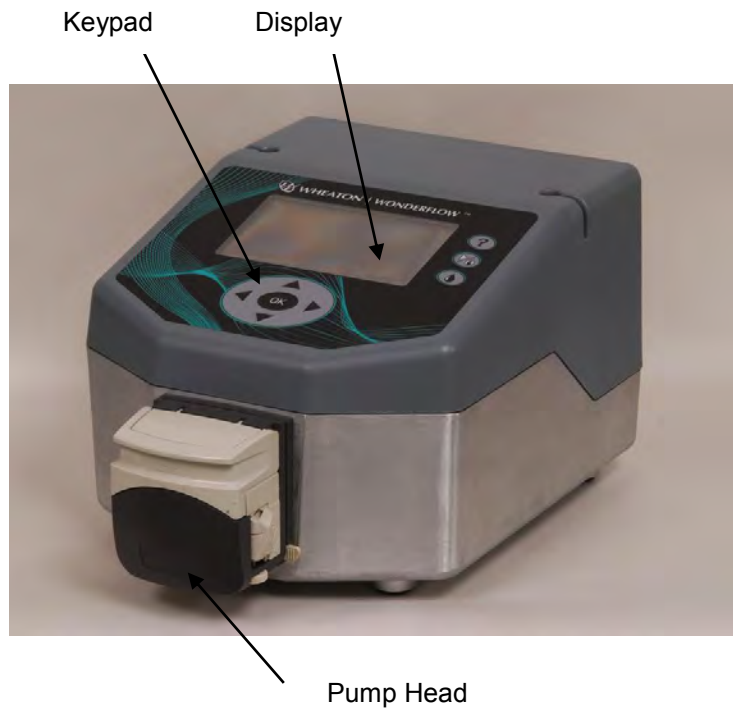

**FIGURE B – Lower Housing Assembly**

ITEM	USE QTY.	WHEATON NO.	DESCRIPTION
1	1	50099007	ALUMINUM BASE CABINET
2	1	WI056857	PCBA, REMOTE I/O
3	1	WI056858	MOTOR, STEPPER
4	1	WI056859	UNIVERSAL POWER SUPPLY, 48V, 3.2A
5	1	50099058	POWER SUPPLY STABILIZER BRACKET
6	1	WI056856	PCBA, CPU, OMNISPENSE ELITE
7	1	WI056863	POWER INLET
8	1	WI056860	POWER SWITCH
9	4	50099059	ADHESIVE RUBBER FEET
10	1	50099060	PUMP HEAD DRIVE ADAPTER
11	2	I052353	SCW, SET, #10-32 X 1/4" LG
12	4	50099061	SCW, SET, 10-32 X 1/2" LG
13	4	50099062	SCW, M4X8, SS, PPHM
14	1	I052239	SCW, 6-32 X 1/4 PPHM
15	1	50029919	NUT, HEX, 6-32
16	1	I052273	WASHER, STAR, #6, INT TOOTH
17	1	50099063	STF, 6-32 X 1/4, ALUMINUM
18	2	WI056864	FUSE, 5X20MM, 2.0AT, 250V (120V)
18	2	WI056862	FUSE, 5X20MM, 1.0AT, 250V

**FIGURES C THRU E – Upper Housing Assembly, Main Assembly and Wiring Diagram**

ITEM	USE QTY.	WHEATON NO.	DESCRIPTION
19	1	50099005	PLASTIC UPPER HOUSING, CABINET
20	1	WI056861	LCD, DISPLAY, 240 X 128, BACKLIT
21	1	50099072	CONTROL KEYPAD OVERLAY, UNISPENSE PRO
22	4	50099068	SCW, PLASTITE 48, TRILOBE, #4 X 0.250
23	1	50099006	SCREEN, VENT, PLASTIC
24	4	50099758	#8 X 1-1/4" PHIL PAN HEAD SCREW
25	1	50099065	ASS'Y, WIRE HNS, OMNI ELITE
26	1	50028826	LABEL, LINE VOLTAGE
27	1	50027794	LABEL, UL APPROVED, SERIAL #
28	1	50028394	LABEL, MET NRTL LISTED, OMNI / FLOW
29	1	50028414	LABEL, CAUTION
30	1	50028416	LABEL, CE (MARK) (230V)

UniSpense® PRO is a trademark of WHEATON Industries, Inc.  
 Stylized "W" is a registered trademark of WHEATON Industries, Inc.

Specifications subject to change without prior notice.  
 ©2010 WHEATON Industries Inc.

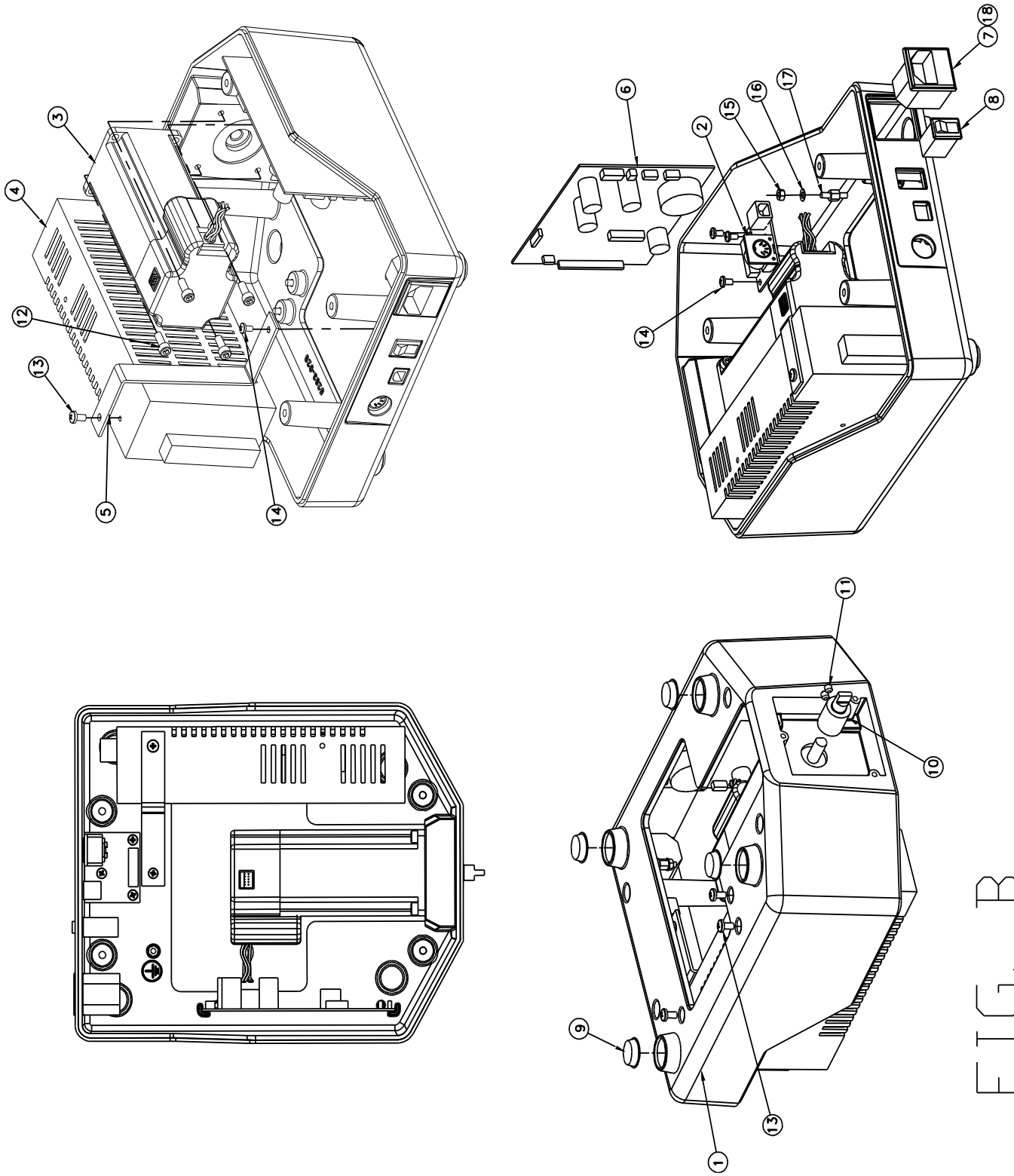

FIG. B

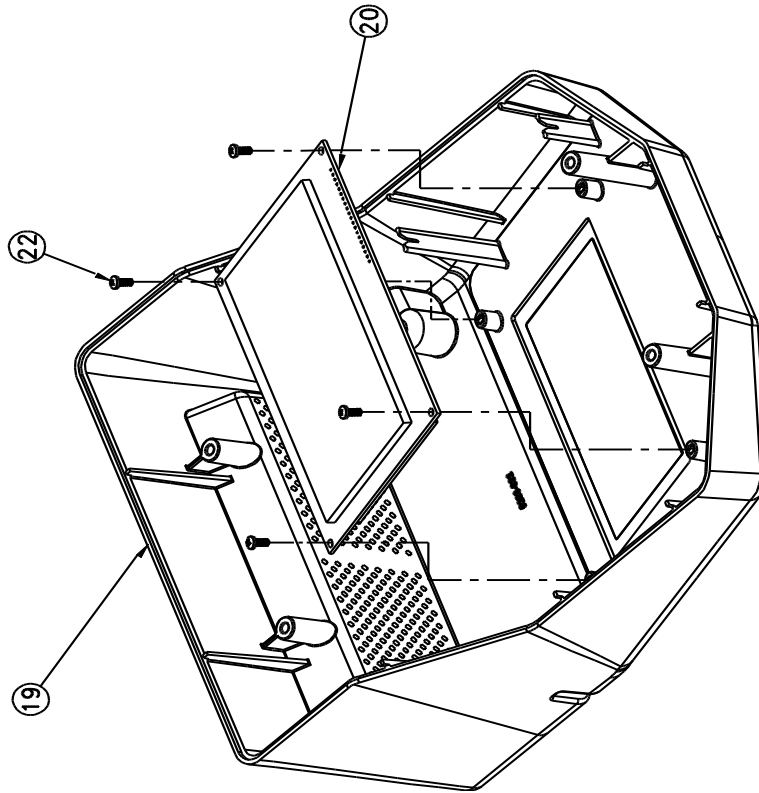
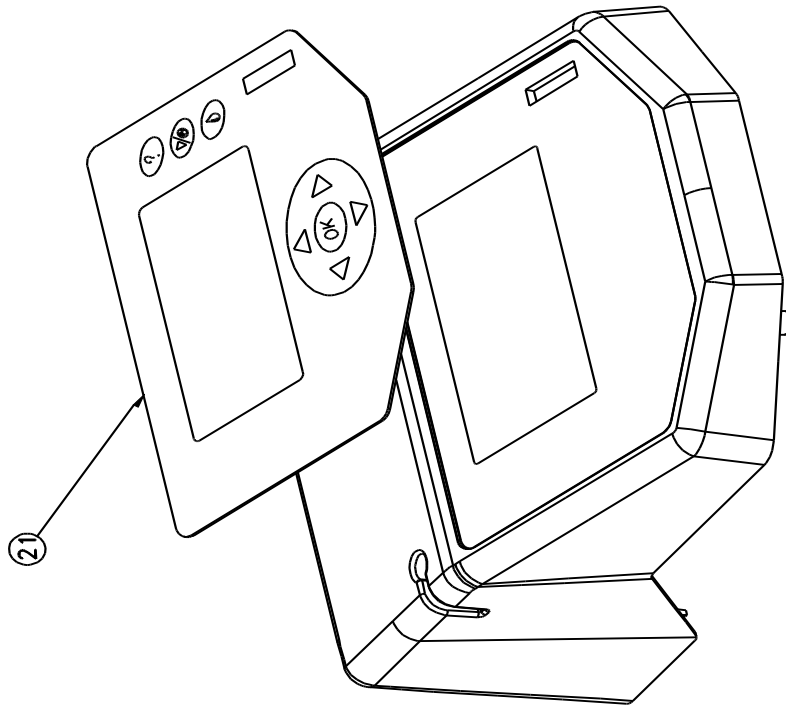
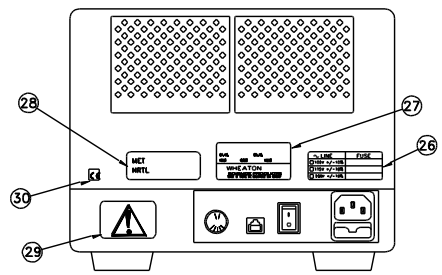
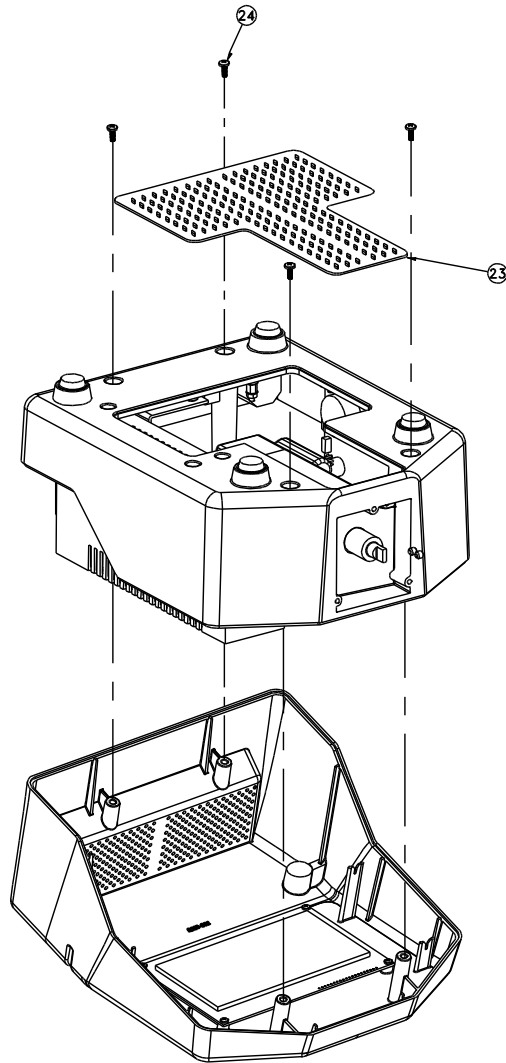

FIG. C





REAR VIEW

FIG. D

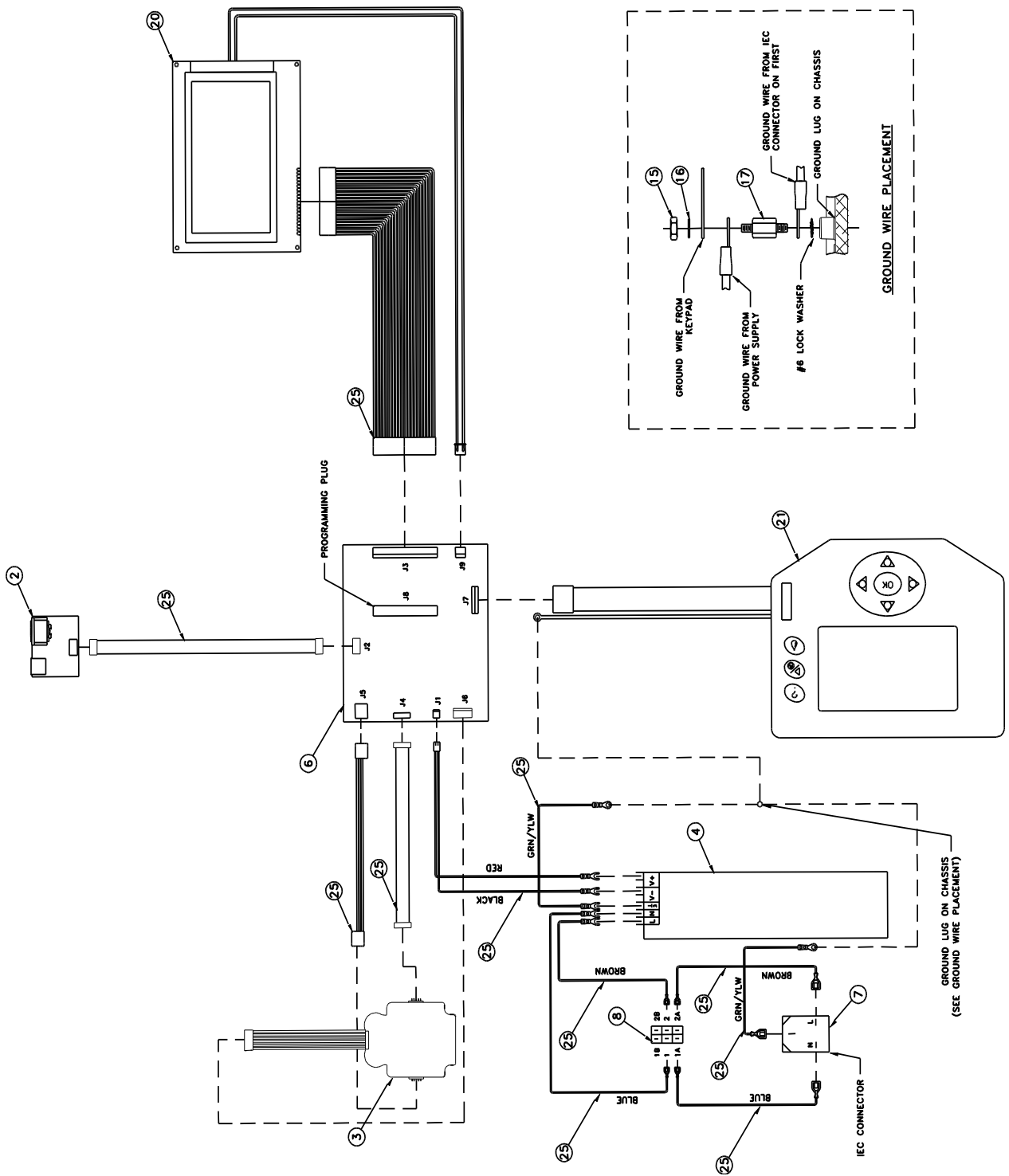
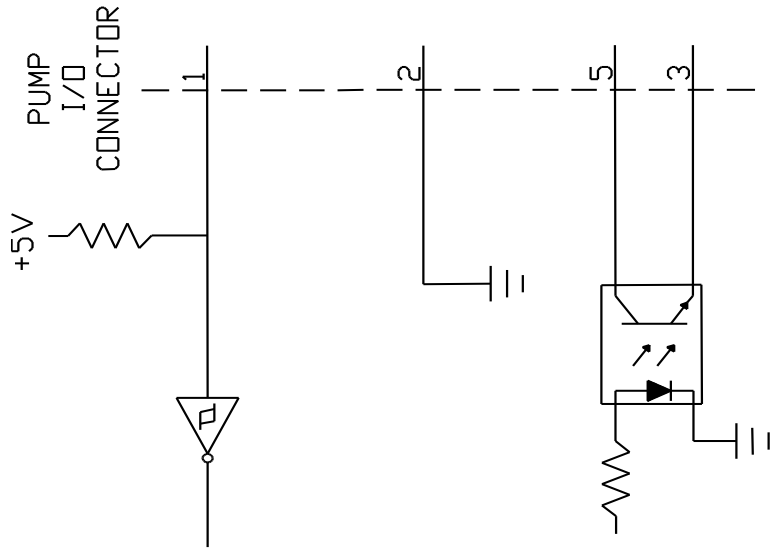
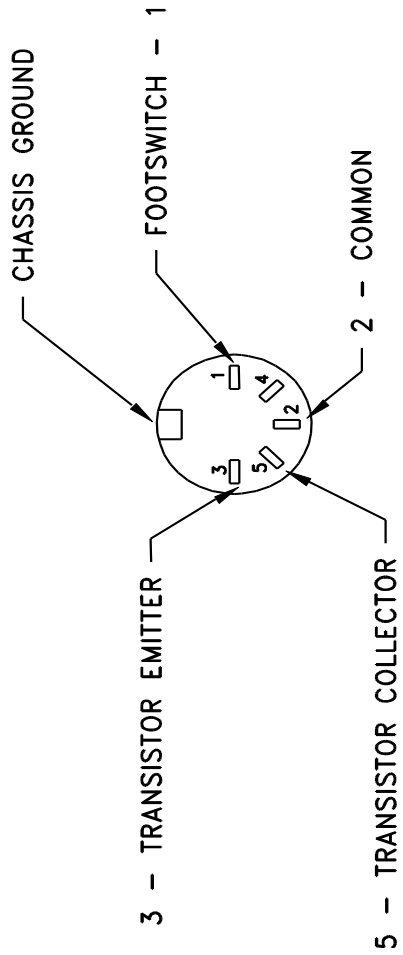

FIG. E



PARTIAL SCHEMATIC



I/O CONNECTOR PINOUT

FIG. F



---

**WHEATON Industries Inc.**

---

***Declaration of Conformity***

We, WHEATON Industries, Inc.  
1501 North 10<sup>th</sup> Street  
Millville, NJ 08332-2038  
USA

Declare that the device described below - marked with CE - fulfills the relevant fundamental EMC and safety requirements specified by the appropriate EU - Directive, with respect to the design and construction of the commercialized version.

This declaration is invalid if modifications are performed on the device which has not been certified by WHEATON Industries, Inc.

Designation of the device: OmniSpense® ELITE / UniSpense® PRO

Relevant Directives:

Standards:

  
\_\_\_\_\_

Nicholas DeBello,  
Director, Quality Systems

9/10/10  
\_\_\_\_\_

Date